

Type	Value
Max Weight	5.7 kg / 12.6 lb
IP Class	IP20
UL Type	Open

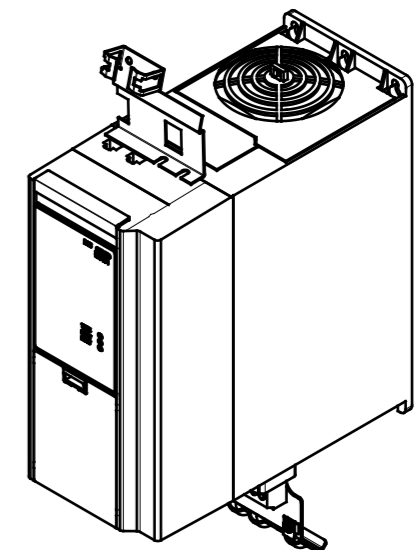

Position of connectors	
A	Line
B	Motor
C	Brake / DC
D	Interface X0
E	Interface X1/X2

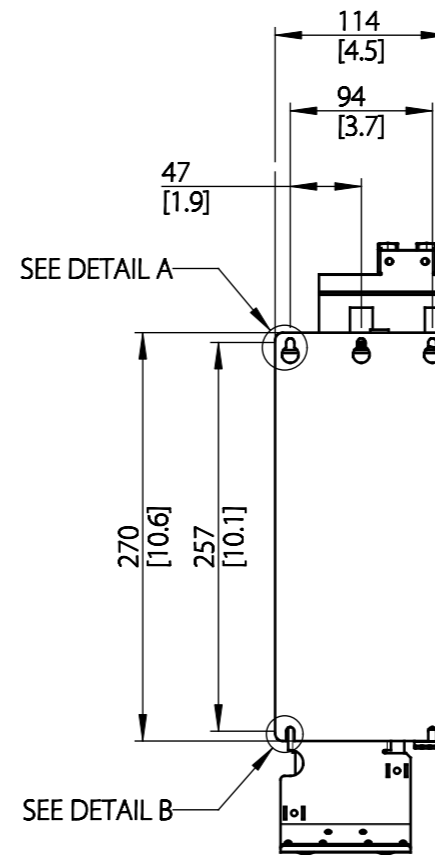
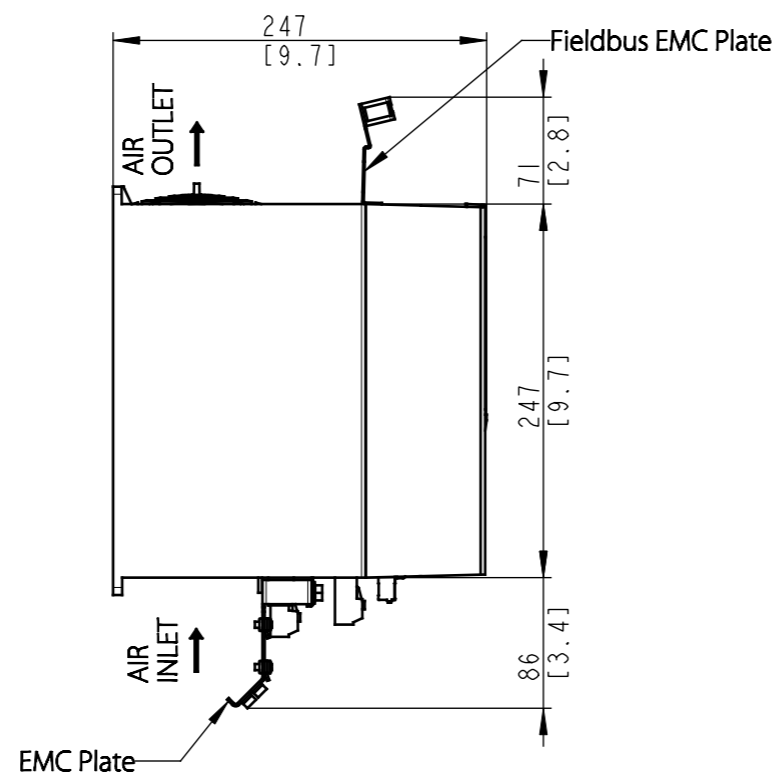
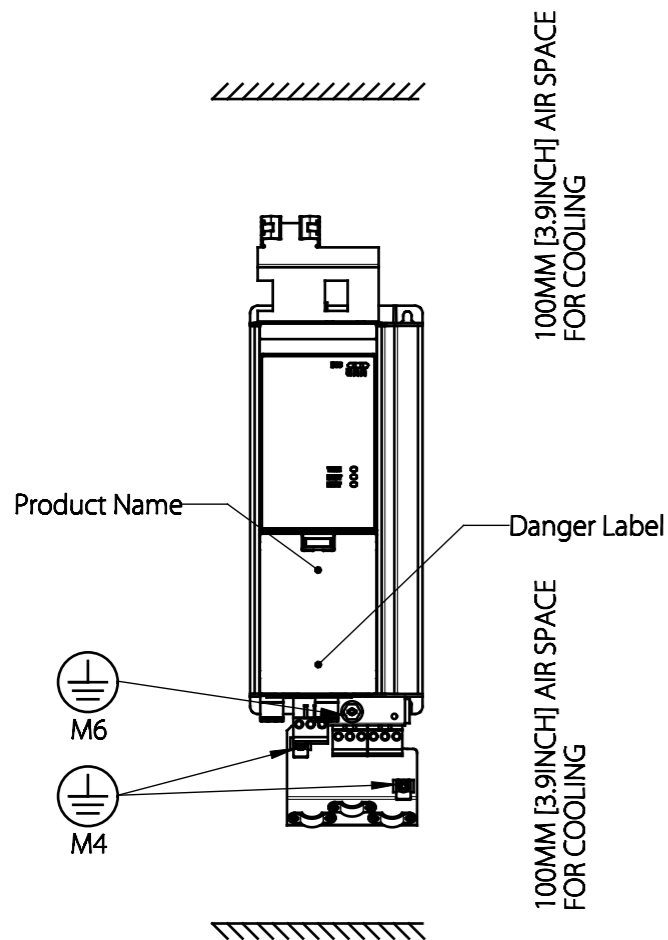
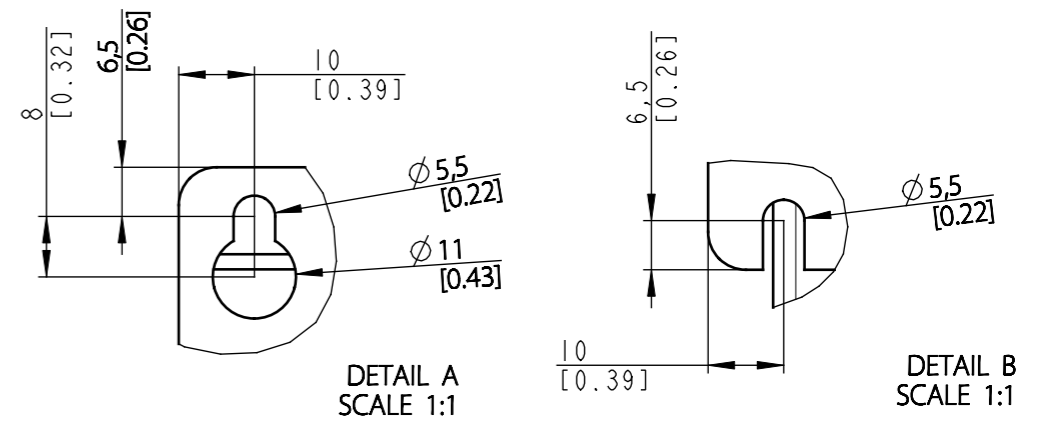
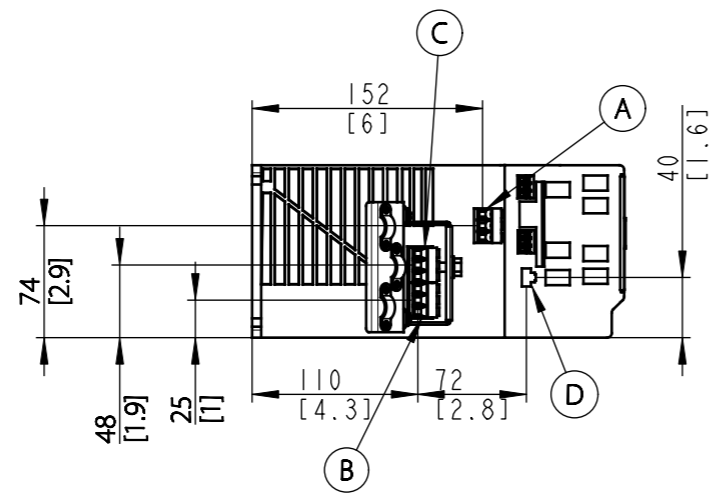
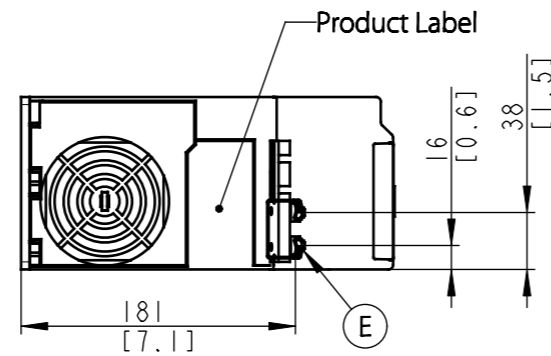

THIS DRAWING SHOWS THE MOST COMMON VERSION OF THIS PRODUCT VARIANT. SMALL DIFFERENCES MAY OCCUR DEPENDING ON THE FINAL PRODUCT CONFIGURATION.

CENTER OF GRAVITY: FOR REFERENCE ONLY, THE PRODUCT CONFIGURATION MAY INFLUENCE THE CG IN ALL THREE AXES.

UNLESS OTHERWISE SPECIFIED THE TOLERANCE IS ± 1 MM [0.4 INCH]. ALL DIMENSIONS ARE IN MILLIMETERS [INCH]		FIRST ANGLE PROJECTION	SCALE 1:5	DRAWING SIZE A3	MATERIAL	
CHANGED			DESCRIPTION MCAD_FA03b_IP20			
DESIGNED	Danfoss					2020-09-11
CHECKED						
PROPERTY OF DANFOSS A/S NORDBOG, DENMARK. TWO OR THREE DIMENSIONAL REPRODUCTION OF CONTENTS TO BE AUTHORIZED BY DANFOSS A/S.					DRAWING NUMBER MCAD_FA03B_IP20	
					REV 001	
					MODEL MCAD_FA03B_IP20	
					SHEET 1 OF 1	