

| Type | Value |
|------------|-------------|
| Max Weight | 178kg/392lb |
| IP Class | IP54 |
| UL Type | Type 12 |

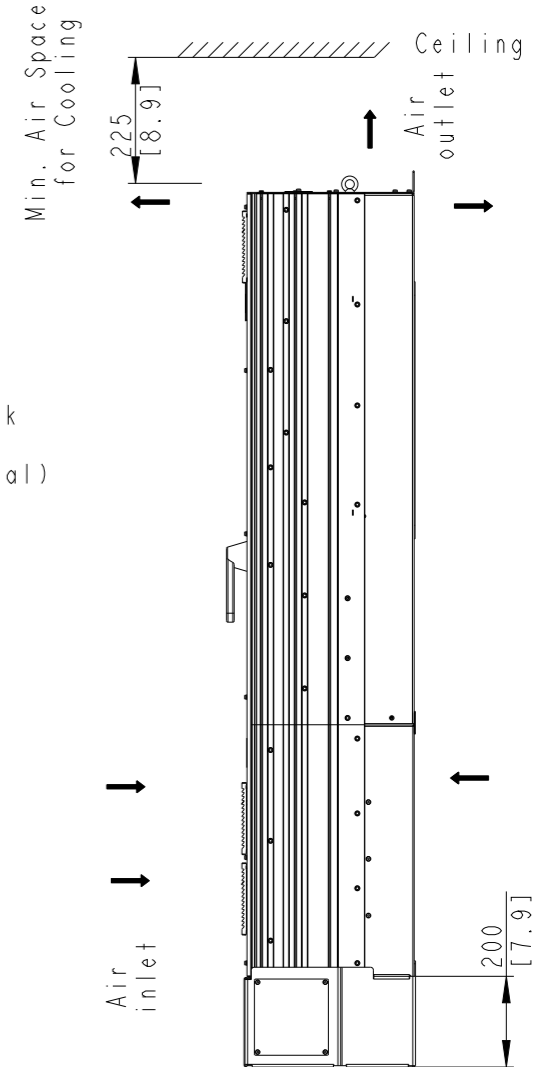
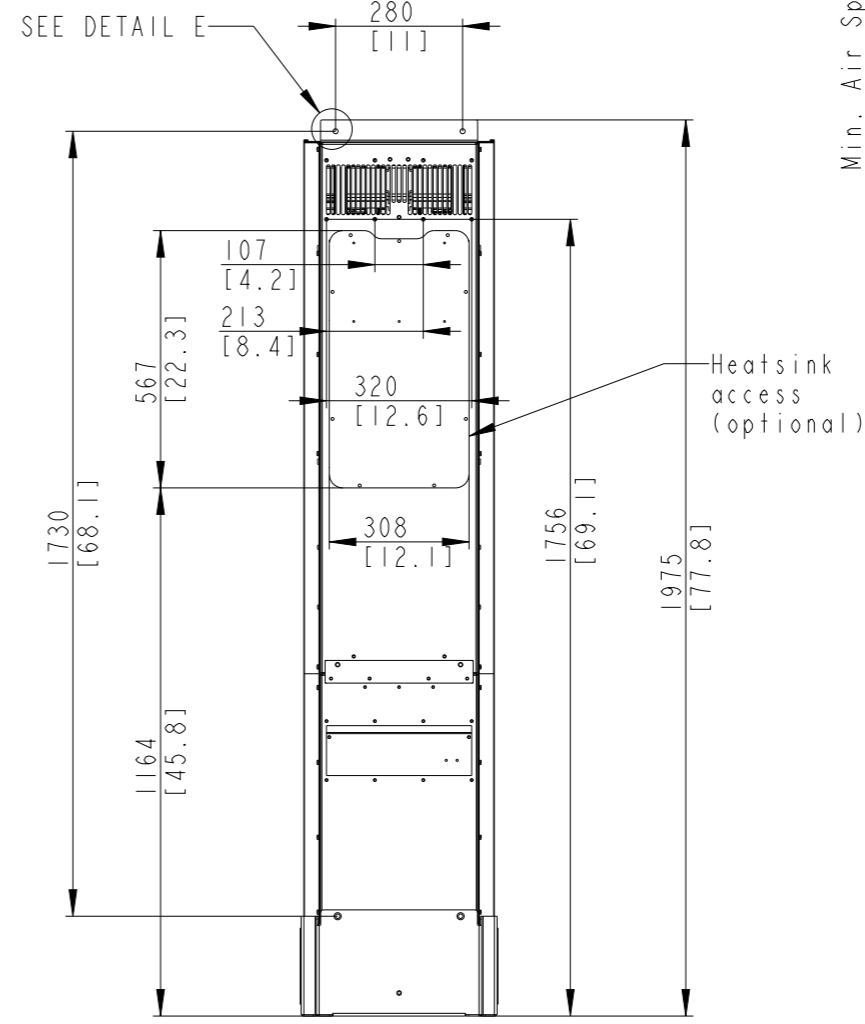
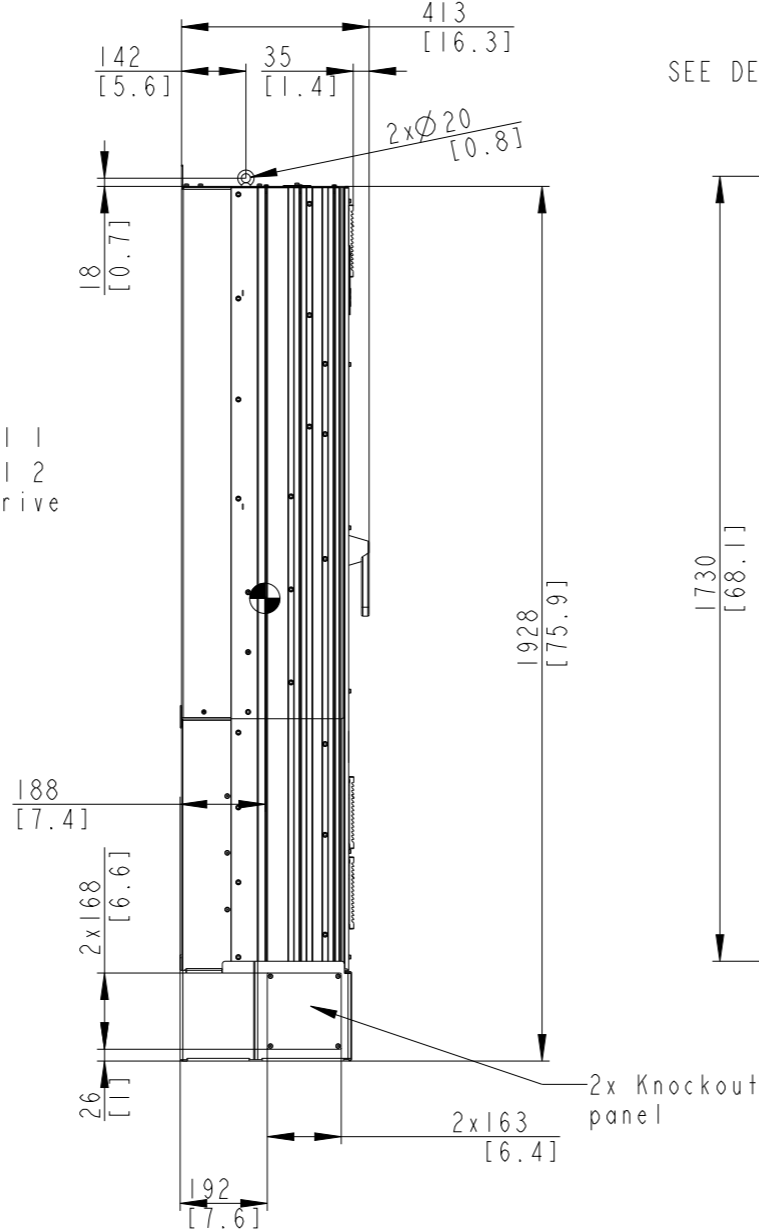
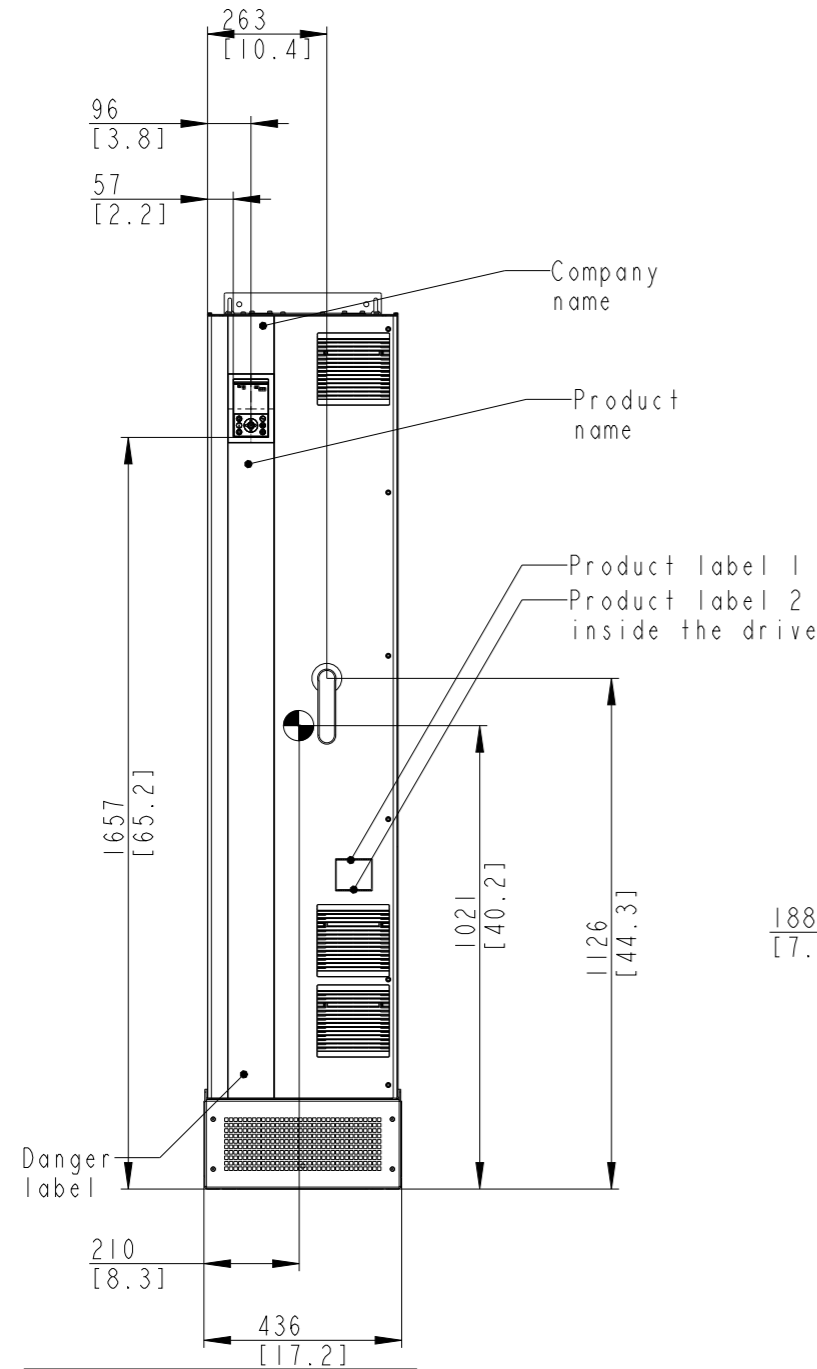
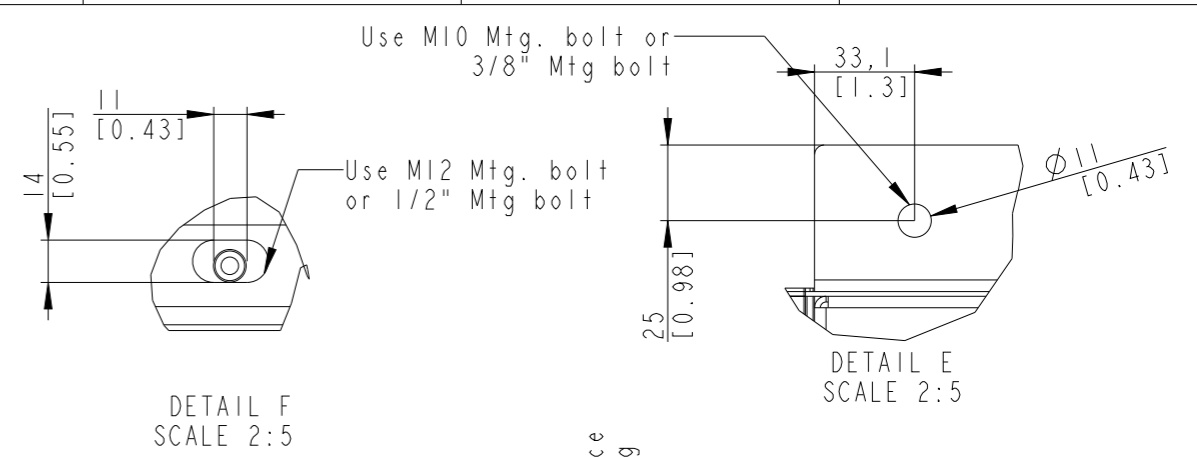
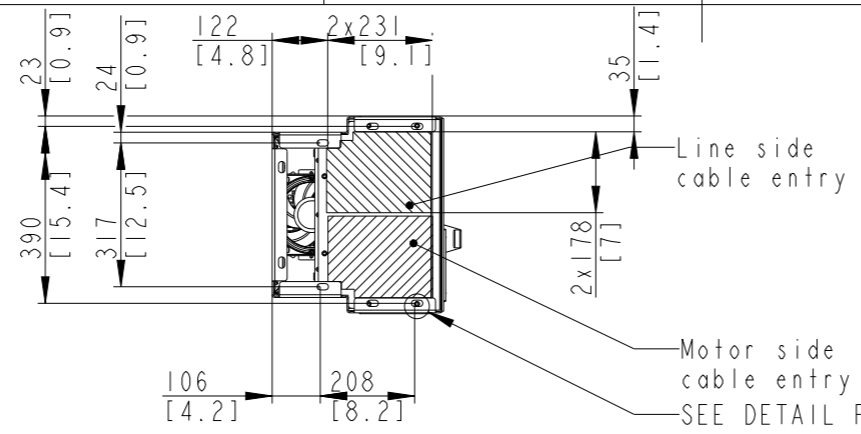

1. MAX AIRFLOW (BACKCHANNEL) - 638m³/hr (375CFM)
2. MAX AIRFLOW (CABINET) - 204m³/hr (120CFM)

| Position of connectors | |
|------------------------|-----------------------|
| A | Line |
| B | Motor |
| C | Brake / DC |
| D | Interface X0 |
| E | Interface XI/X2 |
| F | Grounding connections |

THIS DRAWING SHOWS THE MOST COMMON VERSION OF THIS PRODUCT VARIANT. SMALL DIFFERENCES MAY OCCUR DEPENDING ON THE FINAL PRODUCT CONFIGURATION.

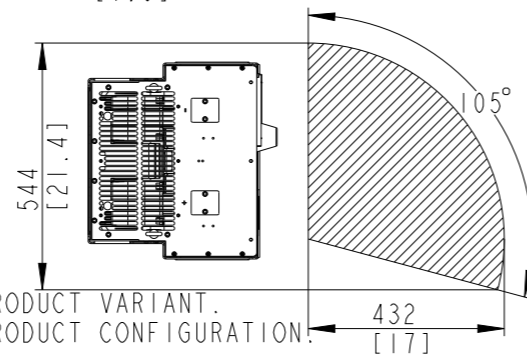

CENTER OF GRAVITY: FOR REFERENCE ONLY, THE PRODUCT CONFIGURATION MAY INFLUENCE THE CG IN ALL THREE AXES.

| | | | | | | | |
|--|----|---------|------------------------|------------|-----------------|-----------------|-----------------|
| UNLESS OTHERWISE SPECIFIED THE TOLERANCE IS ±0.1MM [0.4 INCH]. ALL DIMENSIONS ARE IN MILLIMETERS [INCH] | | | FIRST ANGLE PROJECTION | SCALE 1:20 | DRAWING SIZE A3 | MATERIAL | - |
| | | | | | | FINISH | - |
| | | | | | | DESCRIPTION | |
| | | | | | | MCAD FB10c IP54 | |
| CHANGED | OB | 4/21/25 | | | | DRAWING NUMBER | 178r0018 |
| DESIGNED | OB | 2/3/23 | | | | MODEL | MCAD FB10c IP54 |
| PROPERTY OF DANFOSS A/S NORDBOG, DENMARK. TWO OR THREE DIMENSIONAL REPRODUCTION OF CONTENTS TO BE AUTHORIZED BY DANFOSS A/S. | | | | | | REV | 002 |
| | | | | | | SHEET 1 OF 2 | |

SECTION A-A
Line terminals

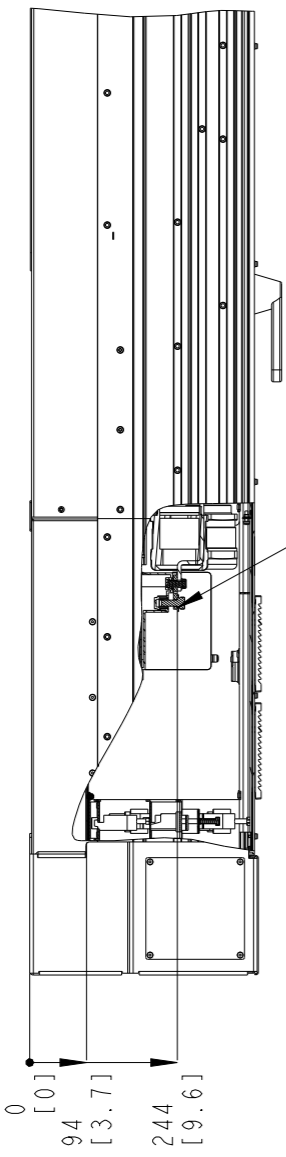

SECTION B-B
MOTOR/BRAKE/DC Terminals

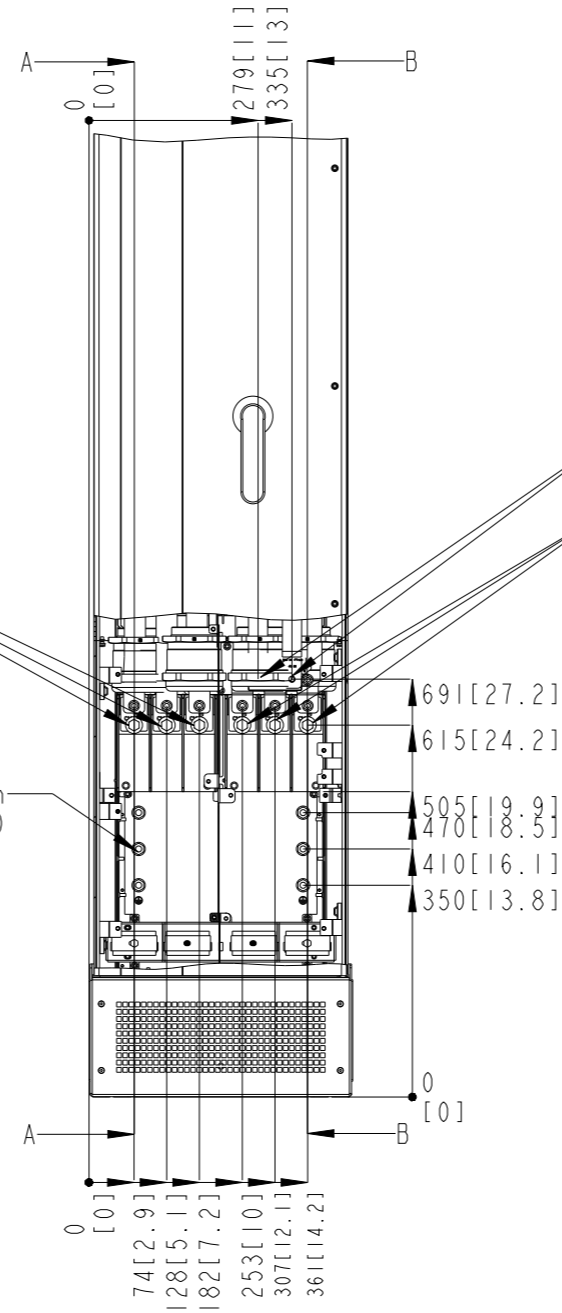
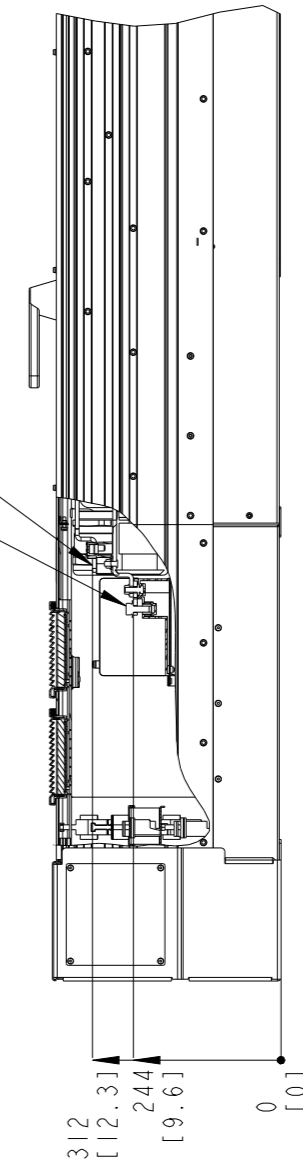

M10x20 stud with nuts (6x)
(F)

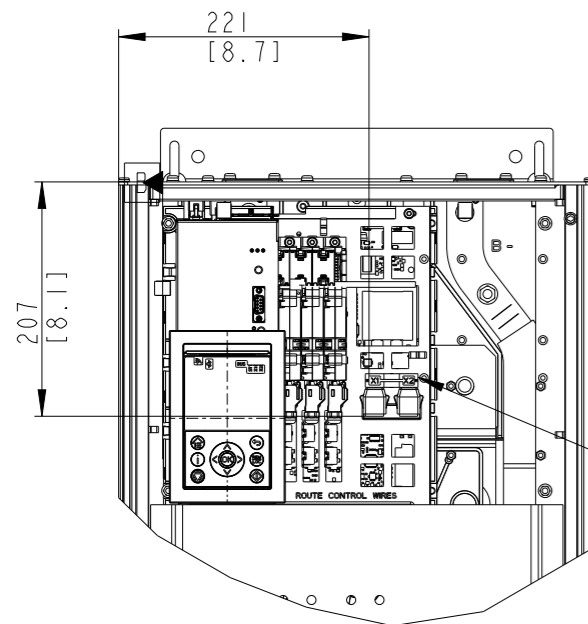

X1&X2 Connector

(L1) (L2) (L3) (U) (V) (W)

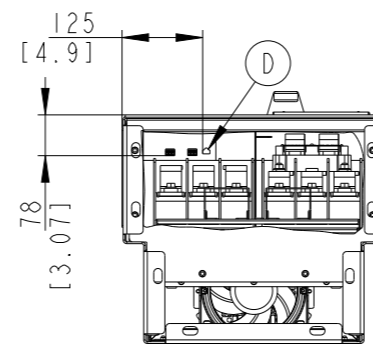

BOTTOM VIEW

LINE TERMINAL

L1, L2, L3

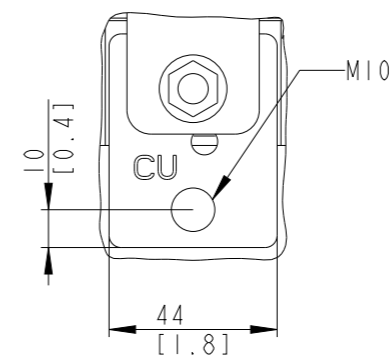

MOTOR TERMINAL

U, V, W

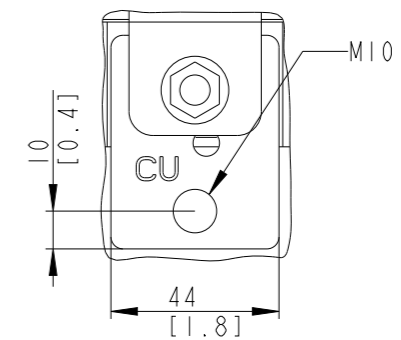

SCALE 1:2

BRAKE / DC TERMINAL

R+, R- DC+, DC-

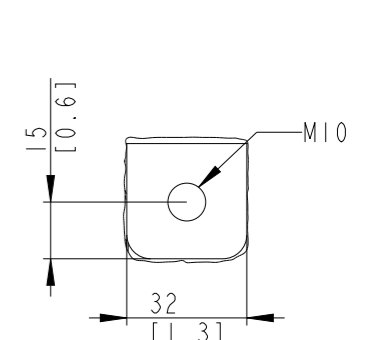

THIS DRAWING SHOWS THE MOST COMMON VERSION OF THIS PRODUCT VARIANT.
SMALL DIFFERENCES MAY OCCUR DEPENDING ON THE FINAL PRODUCT CONFIGURATION.

PROPERTY OF DANFOSS A/S NORDBORG, DENMARK. TWO OR THREE DIMENSIONAL REPRODUCTION OF CONTENTS TO BE AUTHORIZED BY DANFOSS A/S.

| | | | |
|----------------|-----------------|-------|--------|
| DRAWING NUMBER | 178r0018 | REV | 002 |
| MODEL | MCAD FB10c IP54 | SHEET | 2 OF 2 |