

| | |
|------------|------------|
| Type | Value |
| Max Weight | 60kg/132lb |
| IP Class | IP55 |
| UL Type | Type 12 |

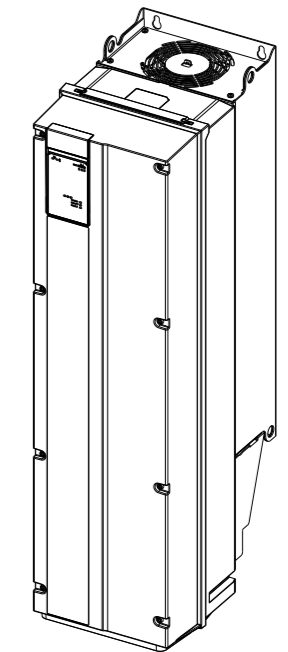

SCALE 2:25

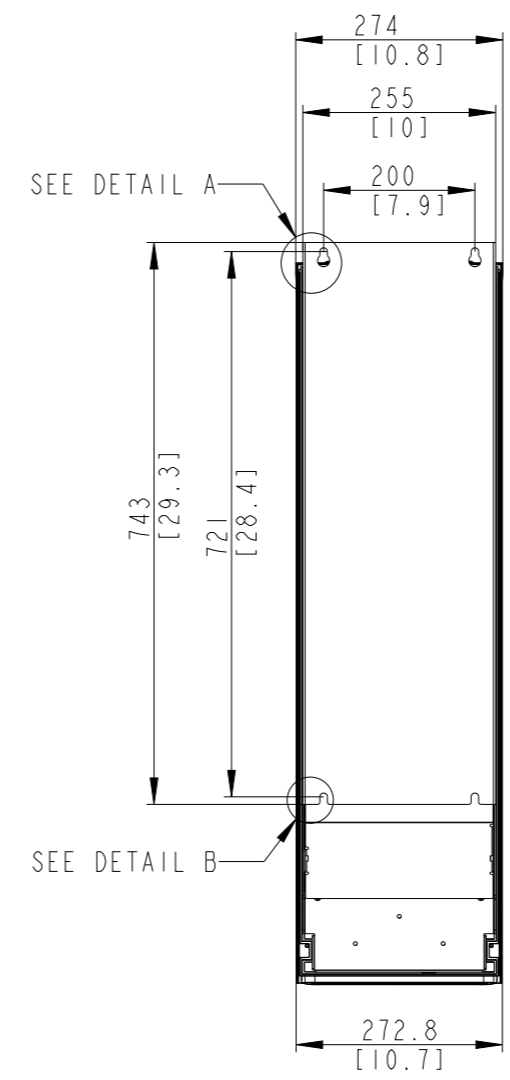
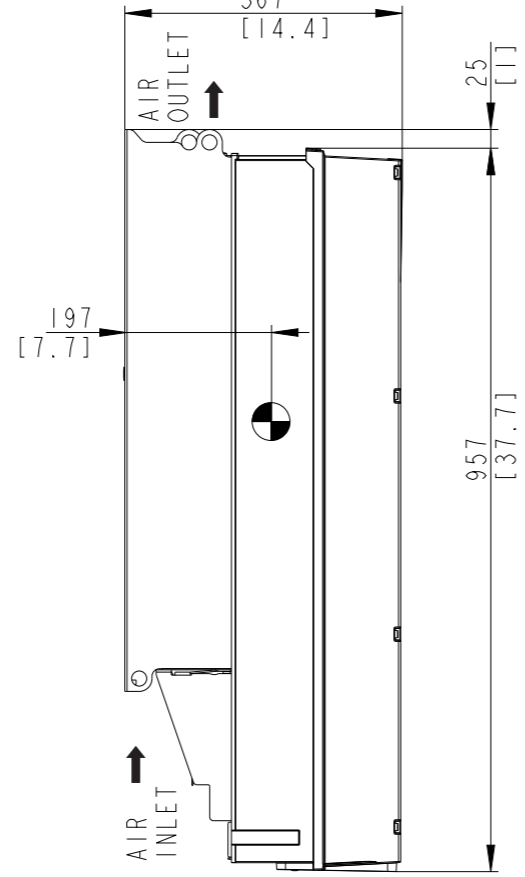
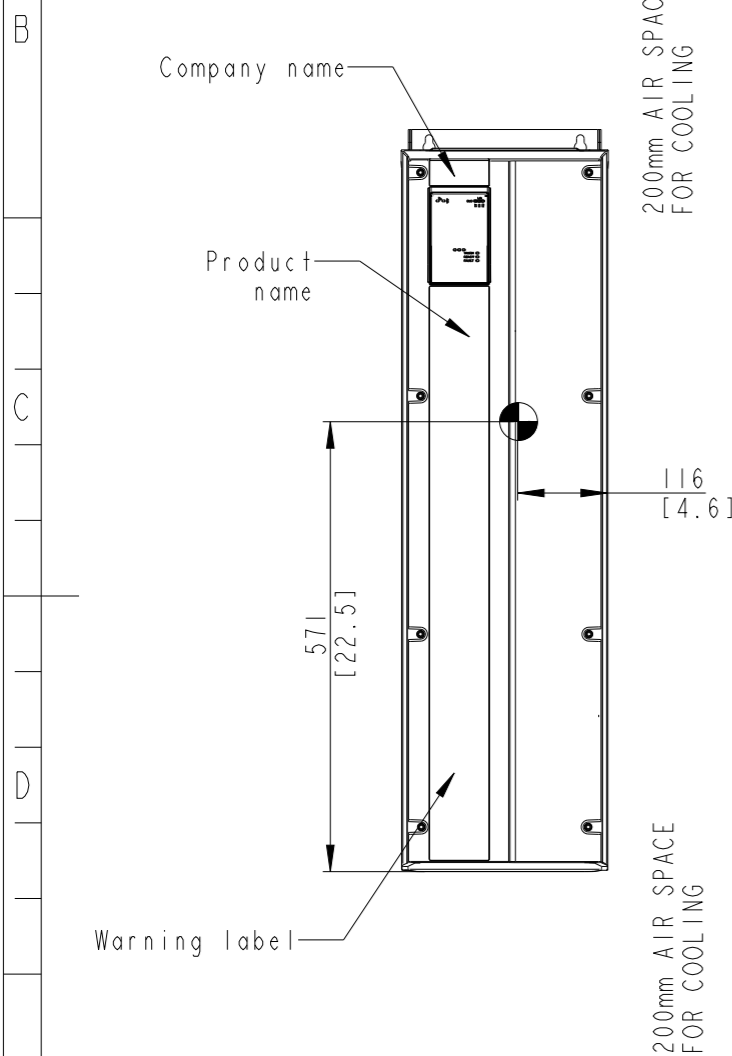
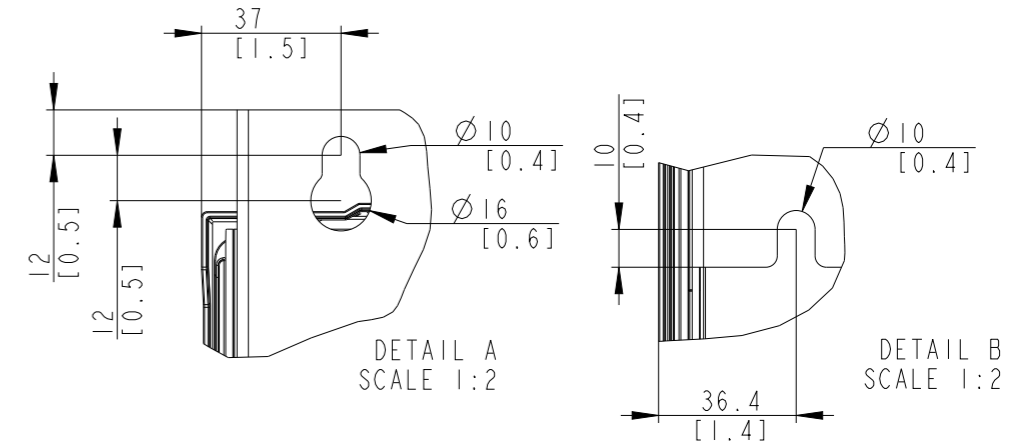
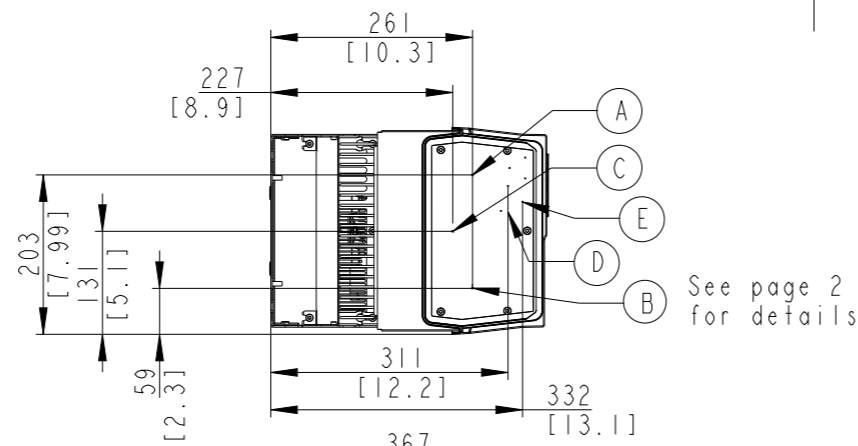
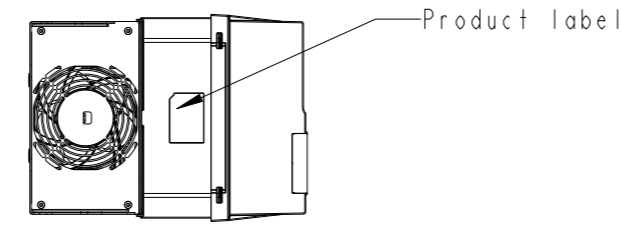

| Position of connectors | |
|------------------------|-----------------------|
| A | Line |
| B | Motor |
| C | Brake/DC |
| D | Interface X0 |
| E | Interface X1/X2 or X4 |

THIS DRAWING SHOWS THE MOST COMMON VERSION OF THIS PRODUCT VARIANT. SMALL DIFFERENCES MAY OCCUR DEPENDING ON THE FINAL PRODUCT CONFIGURATION.

CENTER OF GRAVITY: FOR REFERENCE ONLY, THE PRODUCT CONFIGURATION MAY INFLUENCE THE CG IN ALL THREE AXES.

| | | | | | | |
|---|---------|------------|------------------------|------------|-----------------|----------------|
| UNLESS OTHERWISE SPECIFIED THE TOLERANCE IS $\pm 1\text{mm}$ [0.4 INCH]. ALL DIMENSIONS ARE IN MILLIMETERS [INCH] | | | FIRST ANGLE PROJECTION | SCALE 1:10 | DRAWING SIZE A3 | MATERIAL |
| | | | | | | FINISH |
| | | | | | | DESCRIPTION |
| CHANGED | | | | | | MCAD_FB08_IP55 |
| DESIGNED | Danfoss | 2026-01-23 | | | | |
| CHECKED | | | | | | |
| PROPERTY OF DANFOSS A/S NORDBORG, DENMARK. TWO OR THREE DIMENSIONAL REPRODUCTION OF CONTENTS TO BE AUTHORIZED BY DANFOSS A/S. | | | | | | DRAWING NUMBER |
| | | | | | | MCAD_FB08_IP55 |
| | | | | | | MODEL |
| | | | | | | FB08 |
| | | | | | | REV |
| | | | | | | SHEET 1 OF 2 |

SECTION A-A
LINE TERMINAL

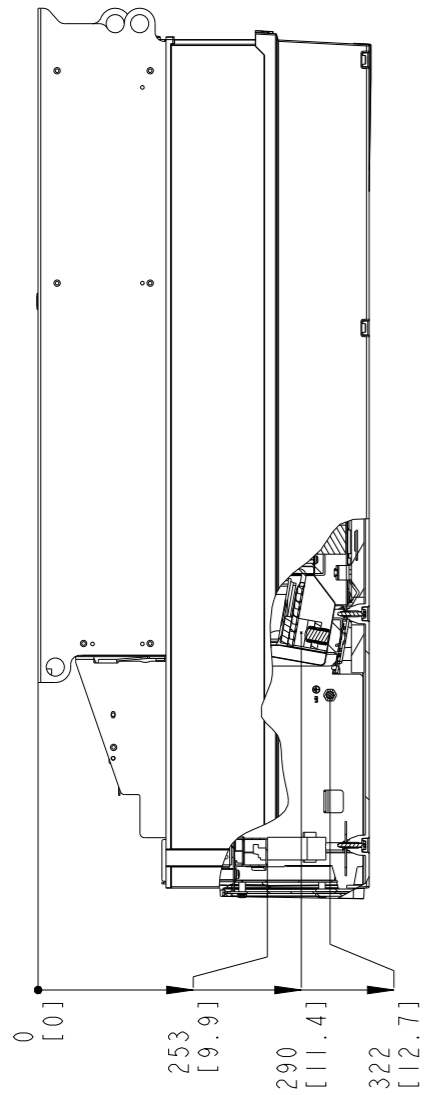

SECTION B-B
MOTOR TERMINAL

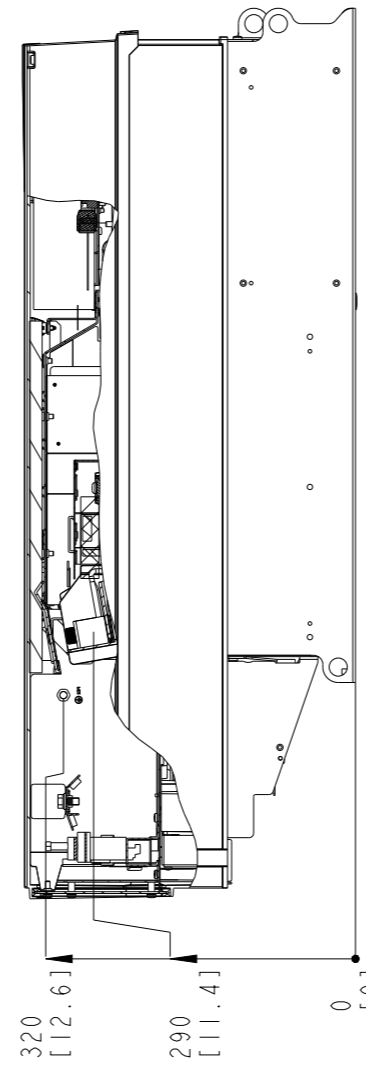

SECTION C-C
DC/BRAKE
TERMINAL

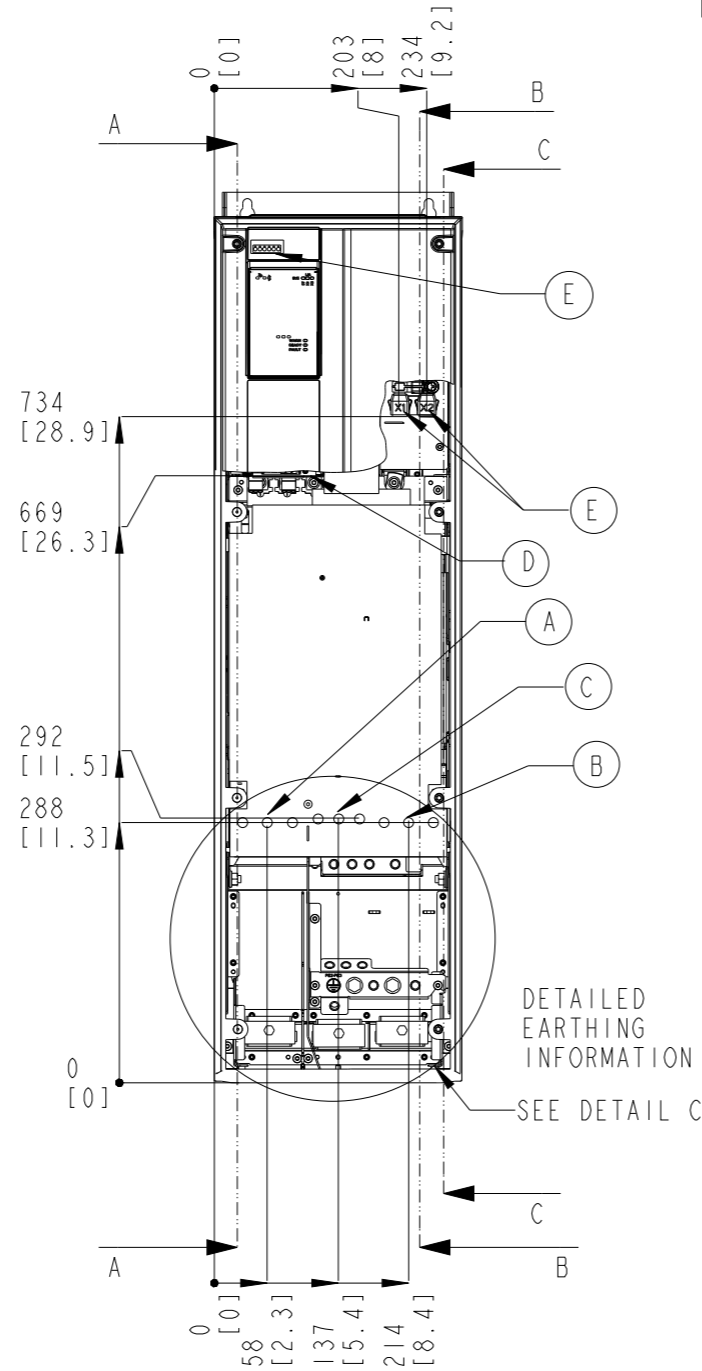
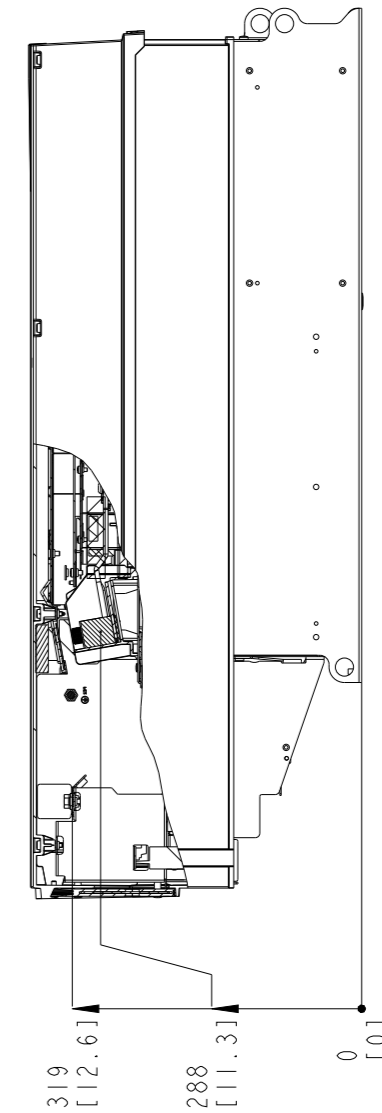

INTERFACE X4

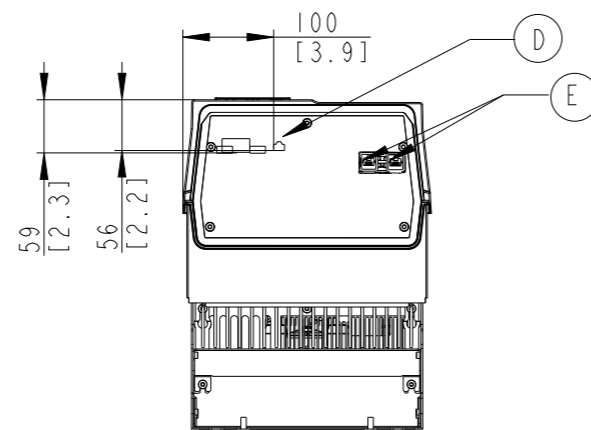
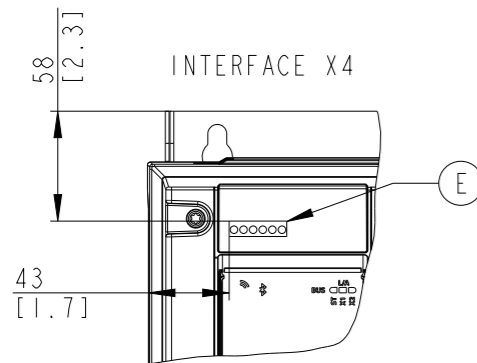

EARTHING INFORMATION

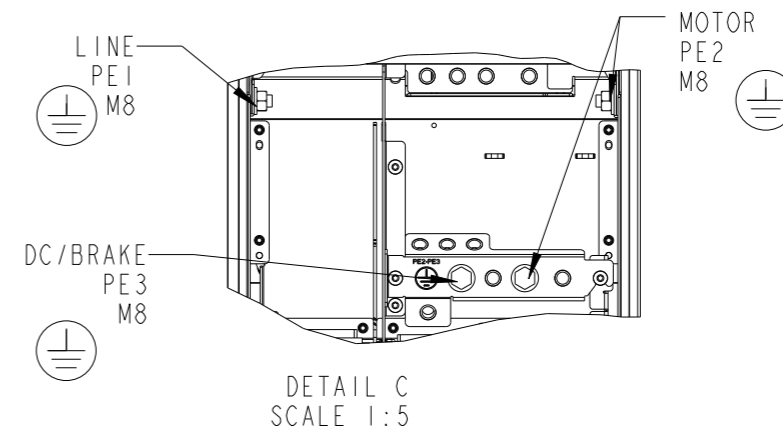

Position of connectors

| | |
|---|-----------------------|
| A | Line |
| B | Motor |
| C | Brake/DC |
| D | Interface X0 |
| E | Interface X1/X2 or X4 |

THIS DRAWING SHOWS THE MOST COMMON VERSION OF THIS PRODUCT VARIANT.
SMALL DIFFERENCES MAY OCCUR DEPENDING ON THE FINAL PRODUCT CONFIGURATION.

PROPERTY OF DANFOSS A/S NORDBOG, DENMARK. TWO OR THREE DIMENSIONAL REPRODUCTION OF
CONTENTS TO BE AUTHORIZED BY DANFOSS A/S.

| | | |
|----------------|----------------|-----------------|
| DRAWING NUMBER | MCAD_FB08_IP55 | REV |
| MODEL | FB08 | SHEET 2 OF 2 |